

Overnight Sleeper for Panel-vans



By modifying the existing bulkhead the 'Overnighter' offers overnight accommodation in Ford Transit & Mercedes Sprinter High Roof Panel Vans. During the day normal delivery operations can continue as it folds up & out of the way, then at night it can be lowered over a 'euro pallet' without the need to enter the rear of the vehicle.



Europe's cab conversion and aerodynamic specialists



For more information contact :
Hatcher Components Ltd.
Broadwater Road, Framlingham. Suffolk . IP13 9LL
Tel:- 01728 723675 Fax:- 01728 724475
Info@hatchercomp.co.uk www.hatchercomp.co.uk



Technical Data

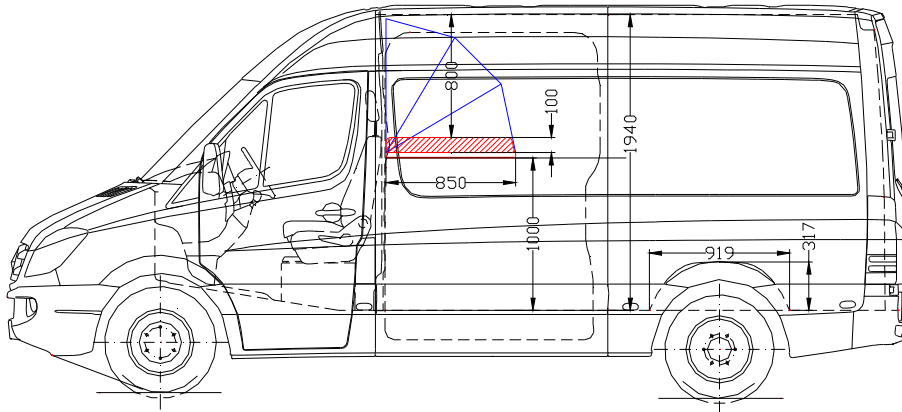

- Mounts to existing bulkhead fixing points
- Can be fitted on-site, supplied as complete kit.
- Able to accept a Euro-pallet when deployed.
- When stowed enters rear of vehicle by less than 120mm
- Operated and entered from driving compartment
- Insulated from cargo area, materials to match cab interior

Optional extras:-

- Curtains to front & side windows
- Night heater

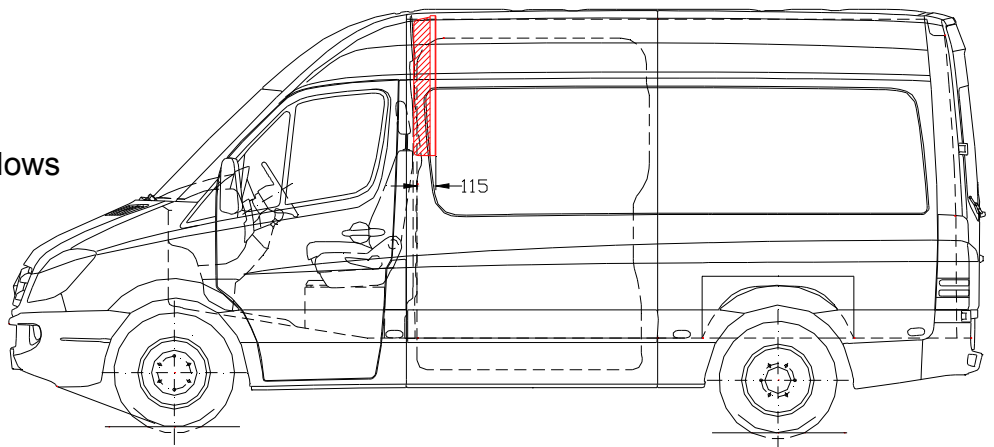

Europe's cab conversion and aerodynamic specialists



For more information contact :
Hatcher Components Ltd.
Broadwater Road, Framlingham. Suffolk . IP13 9LL
Tel:- 01728 723675 Fax:- 01728 724475
Info@hatchercomp.co.uk www.hatchercomp.co.uk

